

**Montage**

1. Trägerklammer ansetzen, Spannschraube handfest anziehen (Kontermutter falls nötig zurückdrehen). Spannschraube festziehen: 1 bis max. 1½ Umdr.

**Nennlast**

Gruppe TCS 1: 5,0 kN

Diese Nennlasten gelten nur für neue TCS am unbeschädigten Trägerflansch.

2. Kontermutter festziehen.

**Installation**

1. Position Beam Clamp. Hand-tighten clamping bolt (if necessary, unscrew the locking nut a bit). Tighten clamping bolt down with a spanner: 1 up to 1½ revolutions.

**Max. working load (tension)**  
Group TCS 1: 5.0 kN

The nominal loads indicated apply to new Beam Clamps fixed to undamaged beam flanges only.

2. Tighten locking nut using a spanner.

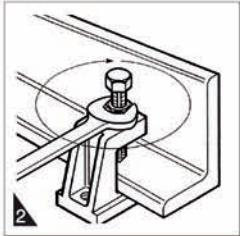

ohne Sicherungslasche  
without Safety Strap



mit Sicherungslasche  
with Safety Strap

**Montagebeispiele**  
Mounting Examples

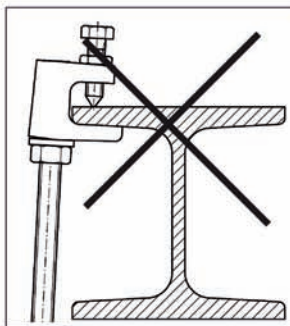
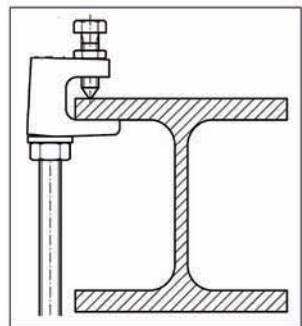

**Achtung!**

- ▶ Anordnung nur bei Parallelfanschträgern erlaubt.

**Caution!**

- ▶ This arrangement is permissible for parallel-flange beams only.

