

Montage

1. Trägerklammer ansetzen,
Spannschraube handfest
anziehen (Kontermutter
falls nötig zurückdrehen).
Spannschraube festziehen:
1 bis max. 1½ Umdr.

Nennlast

Gruppe TCS 1: 5,0 kN

Diese Nennlasten gelten nur
für neue TCS am unbeschä-
digten Trägerflansch.

2. Kontermutter festziehen.

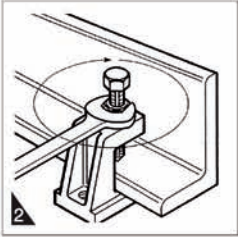

Installation

1. Position Beam Clamp.
Hand-tighten clamping
bolt (if necessary, unscrew
the locking nut a
bit). Tighten clamping bolt
down with a spanner:
1 up to 1½ revolutions.

**Max. working load
(tension)**
Group TCS 1: 5.0 kN

The nominal loads indicated
apply to new Beam Clamps
fixed to undamaged beam
flanges only.

2. Tighten locking nut using
a spanner.



ohne Sicherungslasche
without Safety Strap



mit Sicherungslasche
with Safety Strap

**Montagebeispiele
Mounting Examples**

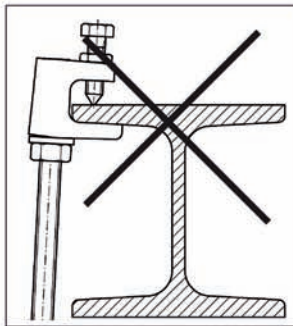
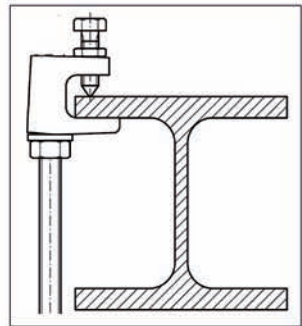

Achtung!

▶ Anordnung nur bei
Pallelfanschträgern
erlaubt.

Caution!

▶ This arrangement is
permissible for parallel-
flange beams only.

